

## InnerRange Concept 2000 Alarm Panel



PERMACONN™  
leaders in wireless security technology

- ✓ **Panel Dialler wiring**
- ✓ **Panel Programming**

### **Background:**

The PM45 & PM1048-3G (v3) communicator now has a terminal block for the connection of the female 611 fly lead (supplied). If the Alarm Panel also has a terminal block for PSTN connection, we recommend you use your own cable between the Alarm Panel dialler and PM45 & PM1048-3G (v3).

This type of installation negates the use of the female 611 fly lead, decreasing your installation time. For four (4), six (6) and eight (8) pin RJ connectors, please refer to manufactures wiring diagram.

There are four minimum requirements from the Alarm panel for successful communication:

- 1) Must have an eight (8) digit primary phone. E.g. 12345678 or 55555555.
- 2) A four (4) digit account number.
- 3) Must be Contact ID format.
- 4) Must be set for tone (DTMF) dialling.
- 5) Optional is open / close reporting, must be enabled for Pocket Secure App.

### **Dialler Lead wiring between Permaconn and InnerRange Concept Alarm Panel:**

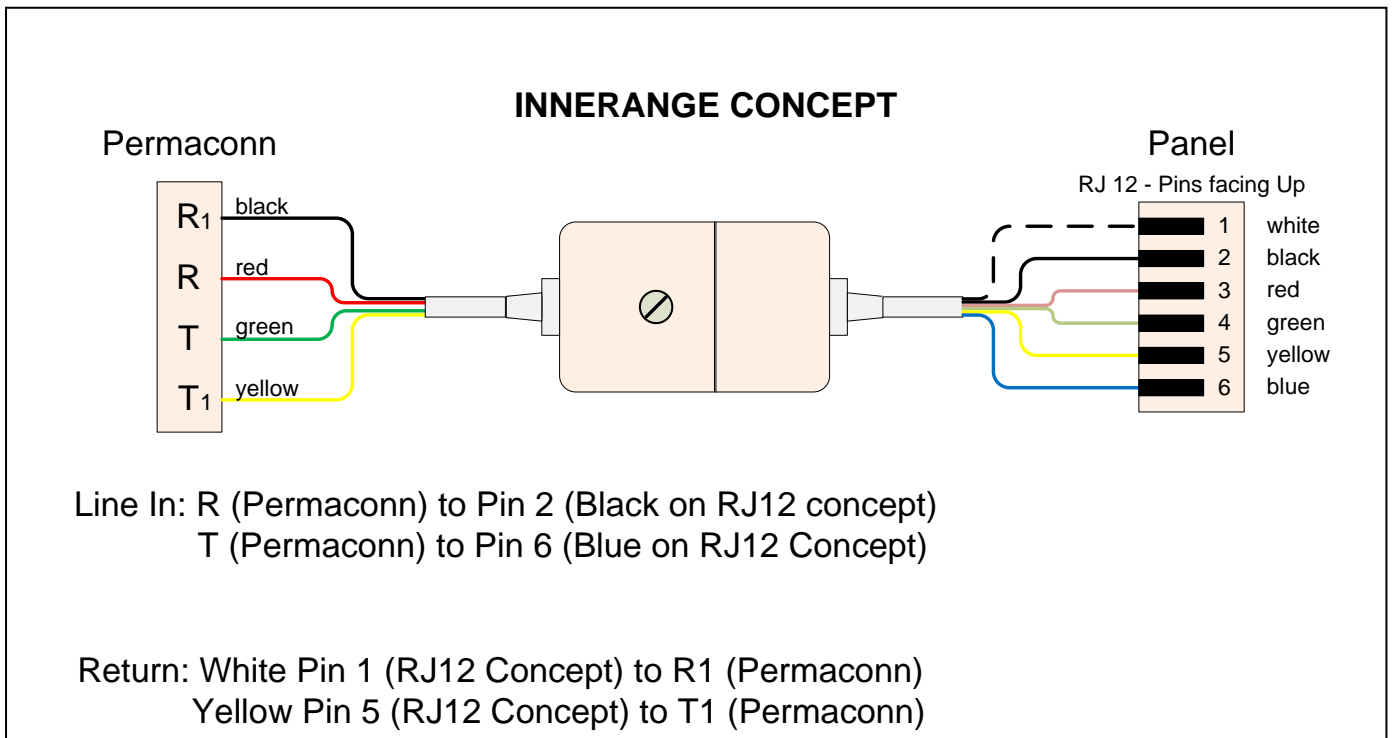

### **Dialler Lead wiring between Permaconn and InnerRange Concept Alarm Panel: cont....**

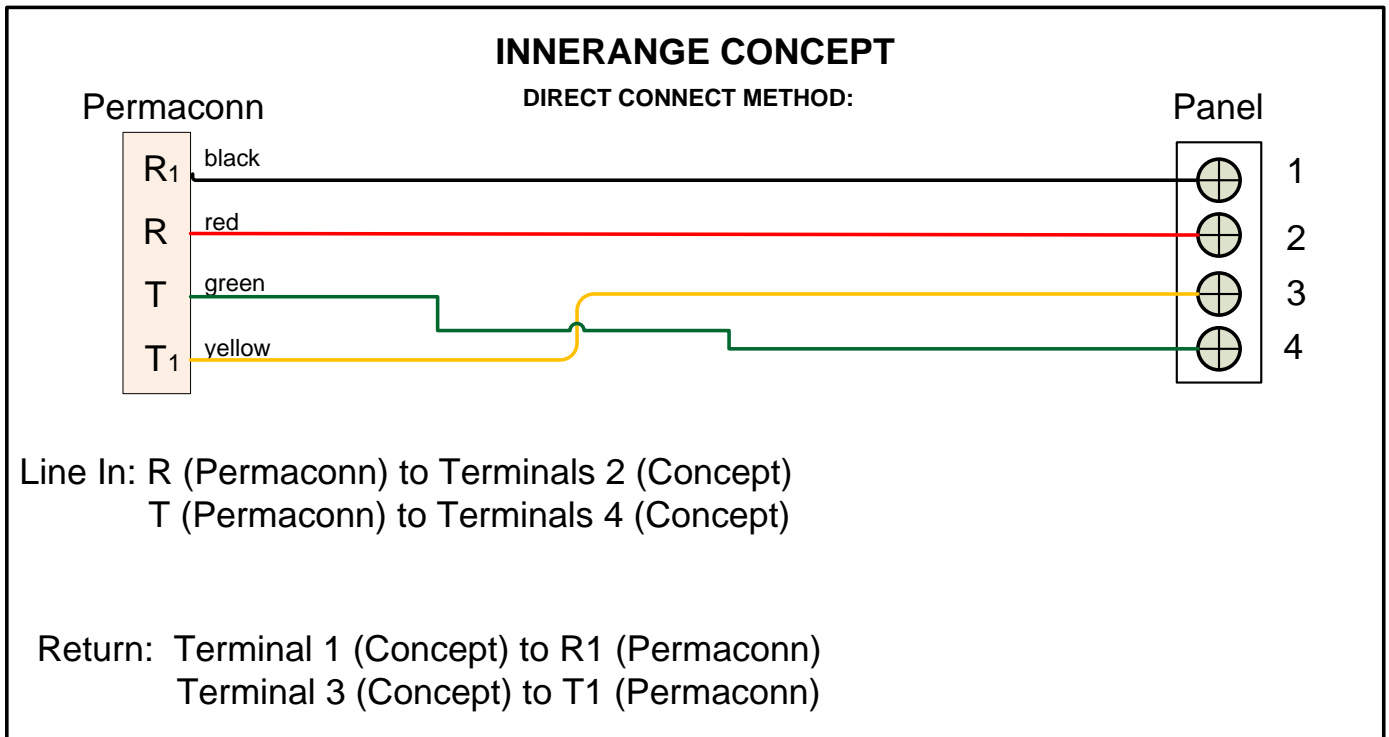

**Access press Menu + 7 + 3 (communications)**

- Current Type: Dialler (use up & down arrows to select available modes ) + press OK button when done.
- Current Type: Dialler (use left arrow to enter communication sub-system select Tone dialling)  
press 9 key to select Y = Yes + press OK button when done.
- Client code: Hard ID/Account N# (N# > N# > N# > N#) + OK button when done.
- Primary Number: min 8digits (N# > N# > N# > N# > N# > N# > N# > N#) + press OK button when done.
- Backup Number: No backup number required + press OK button when done.
- Call back Number: DO NOT USE (leave empty) + press OK button when done.
- Client Number: DO NOT USE (leave empty) + press OK button when done.
- PABX Number: DO NOT USE (leave empty) + press OK button when done.
- Format Selection: Contact ID (use up & down arrows to select available modes ) + press OK button when done.
- Personnel Dialling: DO NOT USE (leave empty) + press OK button when done.
- Press END to exit program mode