

Texecom Premier 816 Alarm Panel



PERMACONN™
leaders in wireless security technology

- ✓ **Panel Dialler wiring**
- ✓ **Panel Dialler programming**

Background:

The PM45 & PM1048-3G (v3) communicator now has a terminal block for the connection of the female 611 fly lead (supplied). If the Alarm Panel also has a terminal block for PSTN connection, we recommend you use your own cable between the Alarm Panel dialler and PM45 & PM1048-3G (v3).

This type of installation negates the use of the female 611 fly lead, decreasing your installation time. For four (4), six (6) and eight (8) pin RJ connectors, please refer to manufactures wiring diagram.

There are four minimum requirements from the Alarm panel for successful communication:

- 1) Must have an eight (8) digit primary phone. E.g. 12345678 or 55555555.
- 2) A four (4) digit account number.
- 3) Must be Contact ID format.
- 4) Must be set for tone (DTMF) dialling.
- 5) Optional is open / close reporting, must be enabled for Pocket Secure App.

Dialler Lead wiring between Permaconn and Texecom Premier 816 Alarm Panel:

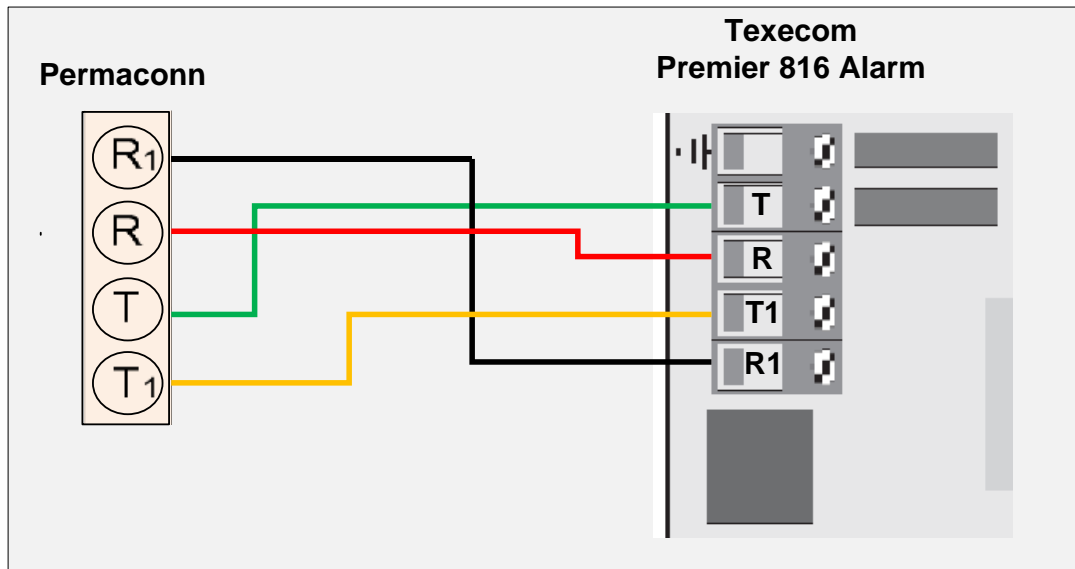

Send Test Report

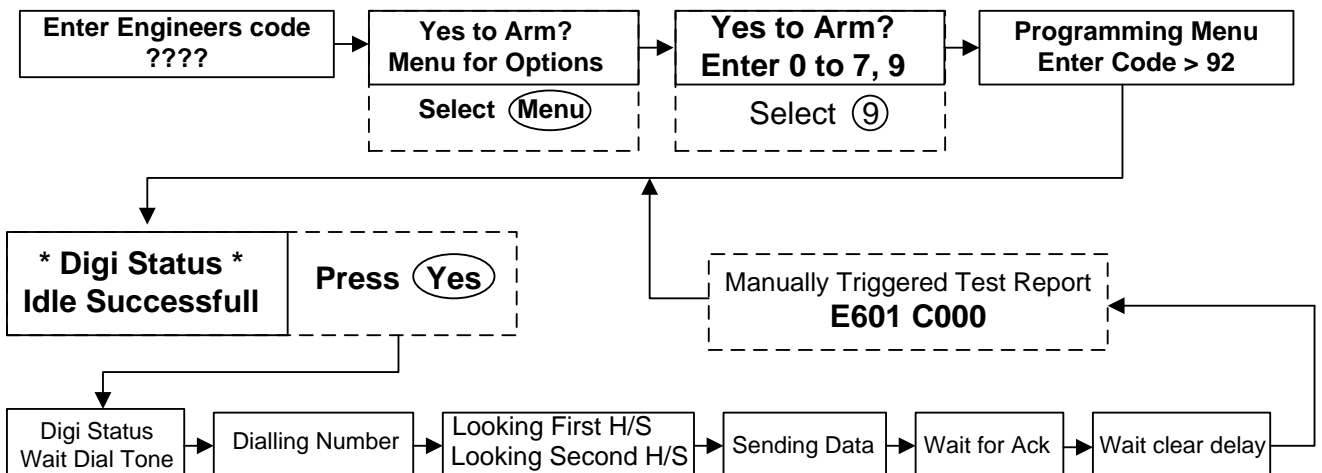

Programming

Enter Engineers code
????
Then press Menu + 9

Note
Only Engineer codes that have the "Allow NVM Locking/Communicator Programming" option are allowed to access menus 70 - 79.

Led Key

- Off
- On
- Slow Flash
- Fast Flash

Programming Menu
Enter Code > ??

Digi Options
> 123 **** 8 <

Use keys (1) - (8) to select/deselect Options.
Then press (Yes) or (Arm)

Communicator Options

- (1) Enable On-Board Communicator
- (2) Enable DTMF Dialling
- (3) Switch to Pulse Dialling after 3rd Attempt
- (8) Enable Blind Dialling

(7) (0)

(7) (1)

Alarm Receiving Center 1 Menu

ARC No.1 Menu
Enter Option 0-8

(0) → **Primary Tel No**

Pri No.>

Enter Telephone Number
Then press (Yes) or (Arm)

Secondary Tel No NOT required

LED: To display Telephone Number press (Disarm)

(1) → **Account No 1**

Acc No1>

Enter Account Number 1
Then press (Yes) or (Arm)

LED: To display Account Number press (Disarm)

Press (Area) to toggle Account No 1/2/3/4.

(2) → **Protocol / Format**

Protocol Contact ID

Enter (4) Contact ID

(3) → **Dial Attempts**

Dial Attempts
Enter Value: 003

Enter Value (0) - (9).
LCD: Use (Down Arrow) to scroll value then press (Yes).

(4) → **Reporting Partitions**

Partitions
> 1234.... <

Use keys (1) - (4) to select/deselect Options.
Then press (Yes) or (Arm)

(5) → **Reporting Events**

Report Events
> 12345678 <

Reporting Events

- (1) Report Priority Alarm and Cancel Events
- (2) Report Alarm and Cancel Events
- (3) Report Open and Close Events
- (4) Report Bypass and Unbypass Events
- (5) Report Maintenance Alarm Events
- (6) Report Tamper Alarm Events
- (7) Report Test Transmission Events
- (8) Report Restore Events

(6) **Pulse Format Options** NOT USED

(7) **Fast Format Reporting** NOT USED

(8) **Protocol Options** NOT USED

(7) (2) NOT USED

(7) (3) NOT USED

(7) (4) NOT USED

(7) (5) NOT USED