

NESS M1

- ✓ **Keyswitch wiring**
- ✓ **Keyswitch programming**



Background: There are three (3) Outputs available.

- Outputs are 'Open Collector' @50mA switching negative - for heavier loads a relay must be used.
- Outputs can be used for e.g. Keyswitch, opening gates or doors etc.
- Ensure there is a common negative between Permaconn and the device being switched.
- The outputs can be Opened, Closed or Pulsed remotely using the Permaconn Atlas web portal.
- The Pocket Secure App can only 'Pulse' the Outputs. A Pulse is approx 1sec.



Compatible with 'Pocket Secure' remote arming App, available on iTunes, Google Play and the Windows Phone Store.

- These outputs when wired to a Keyswitch zone on the Alarm Panel can arm & disarm up to a maximum of three (3) areas when using 'Pocket Secure' app.
- Each area should be independently controlled using a separate Keyswitch zone.
- Arm/Disarm reporting **MUST be Enabled**. Pocket Secure App requires this for its status notifications.
- Test each Output by placing the +ve leg of a multi meter on the +ve terminal that supplies power to the Permaconn, then place the -ve leg of a multi meter on the Output terminal you wish to test. Pulse the selected Output the result should go from 0v DC to 12v DC for approx 1sec and back to 0vDC.

NESS M1 Keyswitch wiring & programming

Reports CID E409 U046 (Disarm)

Reports CID R409 U046 (Arm)

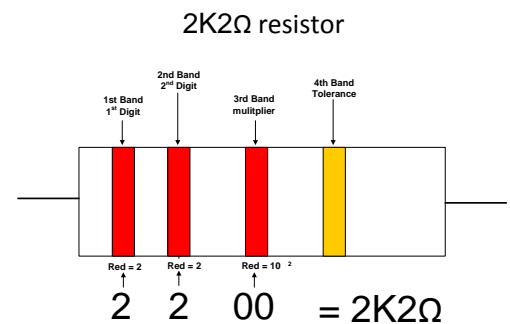
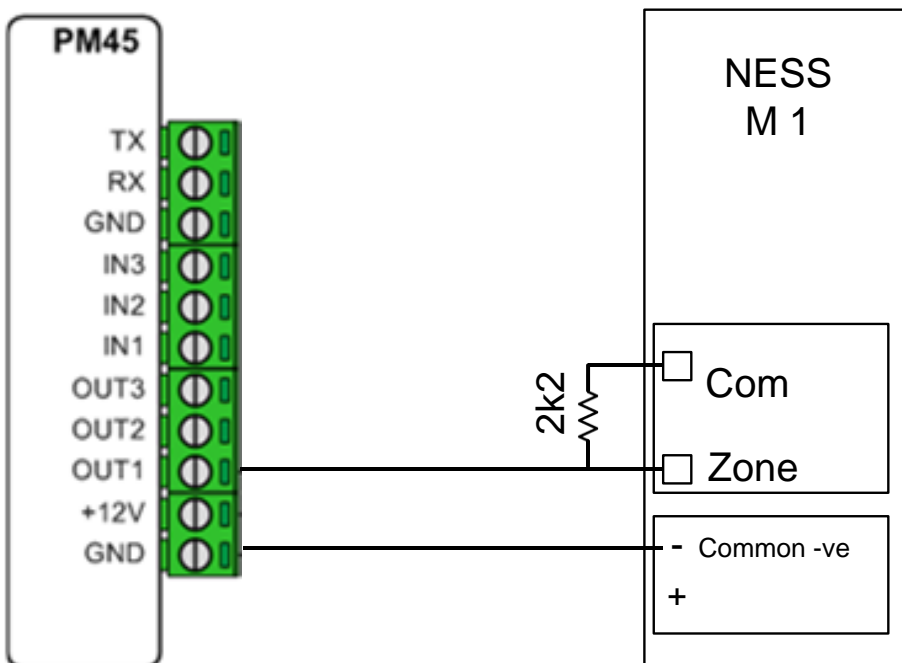

Select menu 05: select zone: Select Type 26 Keyswitch Momentary - Intended for a spring loaded momentary key switch. Toggles the armed state (disarmed/armed) with each trip.

NB: Zones 1 - 16 are defaulted to Hwd 0 = EOL Supervised, 2,200 Ohm resistor